

V O L V O

EC220

Quarry & Aggregates

22.3 t | 167 HP



Volvo Construction Equipment

POWER to perform

Get the most out of your excavator in any application. The EC220 Q&A is equipped with a range of features to ensure a superior performance, shift after shift. Designed with Volvo's extensive experience and expertise, this robust machine delivers ultimate productivity and efficient operation in quarry and aggregate applications.

Powerful Volvo Engine

Experience ultimate power with the EC220 Q&A robust Volvo engine, working together with the machine's proven hydraulics. This engine delivers high torque at low rpm for the ultimate combination of performance and improved fuel efficiency.

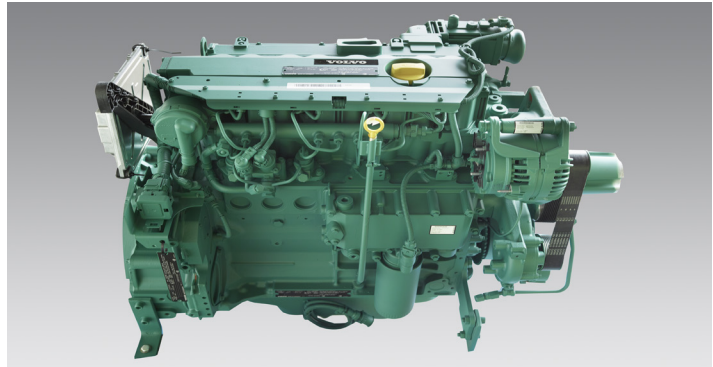

Enhanced operator performance

Operate in comfort for a more productive work shift. The EC220 Q&A is equipped with a spacious and safe operator environment offering enhanced all-around visibility, an adjustable seat and ergonomic controls. The improved cab interior features a new I-ECU monitor that displays a range of information for efficient operation.

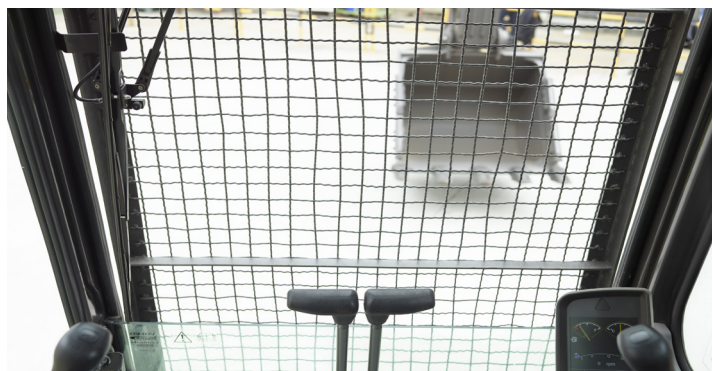

Excellent controllability

The EC220 Q&A features increased hydraulic flow for responsive, accurate control in grading and combined operations. Benefit from smoother and easier movement when traveling and lifting simultaneously as well as better grading quality from the harmonized boom and arm movement.



Efficient work mode

For fast cycle times and optimum fuel consumption, the EC220 Q&A is equipped with the new G4 work mode. Operators can choose the best mode to suit the task at hand, selecting from I (Idle), F (Fine), G (General), H (Heavy) and P (Power max) mode. Choose the correct mode according to your working conditions for added versatility and increased productivity.



EFFICIENCY that lasts

The Volvo EC220 Q&A is a versatile machine that ensures optimum profitability. This excavator is designed to enhance productivity and reduce operating costs, aiming at improving fuel efficiency with help of Volvo's intelligent ECO mode. Excellent service access and a durable design guarantee a long machine life and allow you to get the most out of your machine.

ECO mode

Work efficiently and profitably with Volvo's intelligent ECO mode. This feature contributes to the machine's total improved fuel efficiency – without any loss of performance. The design optimizes flow and pressure while maintaining digging power and swing torque.



Easy to service

The EC220 Q&A is built to ensure servicing is safe, quick and easy, featuring anti-slip plates, grouped filters, ground-level service access and centralized lubrication points. Long service intervals enhance machine availability and increase uptime for maximum productivity.



Genuine Volvo Parts

Volvo Parts are extensively tested and approved because every part is vital for uptime and performance. Only by using Genuine Volvo Parts, you can be sure that your machine retains the renowned Volvo quality.

Superior durability

Benefit from a robust performance, shift after shift. Built with durable components for outstanding results in all applications, the EC220 Q&A is designed to secure lasting machine value and an excellent return on investment.

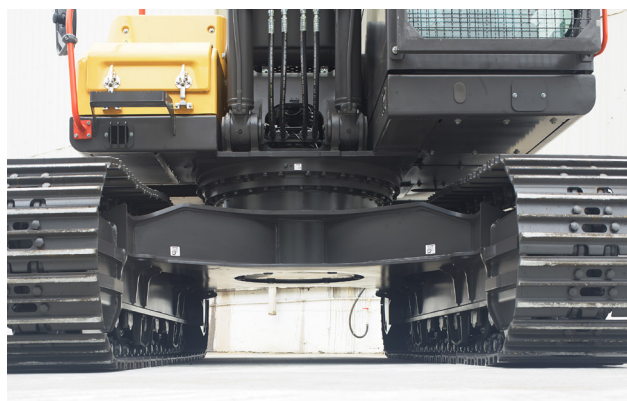

VERSATILITY advantage

With cutting-edge technology, outstanding efficiency and a robust design, the EC220 Q&A can be fitted with a selection of buckets and breaker, that work in harmony with the machine and handles heavy loads with ease. Overcomes rough terrain and delivers outstanding productivity in a variety of jobs and applications by enhancing profitability. Be it general construction, road construction or more specialized work, the Volvo EC220 Q&A is a versatile, high-performance machine designed to achieve outstanding results.

Quality Volvo buckets

Volvo offers a range of high quality buckets designed to perform efficiently in a variety of materials. Featuring exceptional design and built-in durability, these buckets are equipped with Volvo teeth to handle the toughest applications.



Powerful breakers

The EC220 Q&A can be equipped with either a top or side mounted Volvo hydraulic breaker built to break even most demanding materials. With consistent power and high breaking force you'll benefit from maximum impact and durability. Set your Volvo breaker at the right frequency to suit your application needs.



Attachment Management System

Pre-set and adjust hydraulic flow from the monitor inside the cab with this password-protected management system, providing storage for up to 20 different attachments for increased versatility. You can choose between one or two pump flow to maximize profits and productivity.



Optional auxiliary piping

The Volvo-designed hydraulic breaker / shear piping and quick coupler piping option provides optimum flow to the hydraulic attachments. State-of-the-art auxiliary lines allow the correct flow and pressure for special attachments.

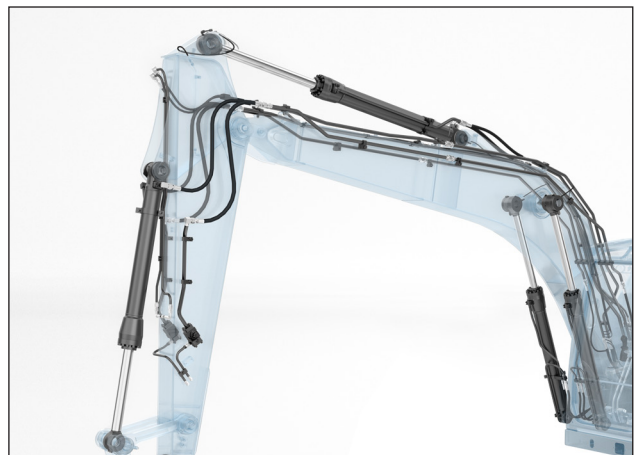

Volvo EC220 Q&A in detail

Engine

The engine, which provide excellent performance, is equipped with four cylinder, vertical, electronic-controlled, high pressure, fuel injectors, turbocharger with waste gate, air-to-air intercooler and water cooled diesel type.

Engine	Volvo	D5E
Max. power at	r/min	2000
Net ISO 9249/SAEJ1349	kW	115
	hp	156
Gross, ISO 14396/SAEJ1995	kW	123
	hp	167
Max. torque	Nm	670
at engine speed	r/min	1600
No. of cylinders		4
Displacement	l	4.7
Bore	mm	108
Stroke	mm	130

Electrical System

Well protected high-capacity electrical system. Waterproof double-lock connectors are used to ensure corrosion-free connection. Main relays and fuses are located in a shielded electrical distribution box. The master switch is standard. Advanced monitoring of machine functions and important diagnostic information is displayed on the I-ECU.

Voltage	V	24
Batteries	V	2 x 12
Battery Capacity	Ah	120
Alternator	V/Ah	28/80
Start Motor	V-kW	24-5.5

Swing System

The swing system uses an axial piston motors, driving a planetary gearbox for maximum torque. An automatic holding brake and anti-rebound valve are standard.

Max. slew speed	r/min	12.3
Max. slew torque	kNm	76.7

Travel System

Each track is powered by an automatic two-speed shift travel motor. The track brakes are multi-disc, spring-applied and hydraulic released. The travel motor, brake and planetary gears are well protected within the track frame.

Max. drawbar pull	kN	183
Max. travel speed (low)	km/h	3.6
Max. travel speed (high)	km/h	5.8
Gradeability	Deg	35

Undercarriage

The idlers, track links, upper and bottom rollers are built to withstand all elements and terrain.

	EC220 Q&A	
Track shoe		2 x 46
Link pitch	mm	190
Shoe width, triple grouser	mm	500/600/700/800/900
Shoe width, triple grouser (HD)	mm	600
Bottom rollers		2 x 7
Top roller		2 x 2

Hydraulic System

The hydraulic system and MCV (main control valve) use intelligent technology to control on-demand flow for high productivity, high-digging capacity and excellent fuel economy. The summation system, boom, arm and swing priority along with boom and arm regeneration provides optimum performance. The following important functions are included in the system:

Summation system: Combines the flow of both hydraulic pumps to ensure quick cycle times and high productivity

Boom priority: Gives priority to the boom operation for faster raising when loading or performing deep excavations.

Arm priority: Gives priority to the arm operation for faster cycle times in levelling and for increased bucket filling when digging.

Swing priority: Gives priority to swing functions for faster simultaneous operations.

Regeneration system: Prevents cavitation and provides flow to other movements during simultaneous operations for maximum productivity.

Power boost: All digging and lifting forces are increased.

Holding valves: Boom and arm holding valves prevent the digging equipment from creeping.

2 x Variable displacement axial piston pumps

Maximum flow	l/min	2 x 212
--------------	-------	---------

Gear pump

Maximum flow	l/min	1 x 18
--------------	-------	--------

Relief valve setting pressure

Implement	MPa	32.4/4.3
Travel circuit	MPa	34.3
Slew circuit	MPa	27.9
Pilot circuit	Mpa	3.9

Hydraulic cylinders

Mono boom		2
Bore x Stroke	ø x mm	125 x 1235
Arm		1
Bore x Stroke	ø x mm	135 x 1540
Bucket		1
Bore x Stroke	ø x mm	120 x 1065
Bucket for LR Boom		1
Bore x Stroke	ø x mm	100 x 865

Service Refill

Fuel tank	1	375
Hydraulic system, total	1	300
Hydraulic tank	1	160
Engine oil	ltr	19.5
Engine coolant	ltr	15
Slew reduction unit	1	8.6
Travel reduction unit	1	2 x 5.8

Cab

The Volvo cab features a brand new Volvo styling including a strong cab structure, slim pillars and a large glass area for good visibility, a spacious cab, an ergonomic switch layout, efficient air ventilation and a pressurized cab.

Sound Level

Sound level in cab according to ISO 6396		
LpA (standard)	dB(A)	73
LpA (tropical)	dB(A)	73.5
External sound level according to ISO 6395, GB16710-2010		
LwA (standard)	dB(A)	102.5
LwA (tropical)	dB(A)	103.5

Specifications

Machine Weights & Ground Pressure - EC220Q&A, 5.7M BOOM, 2.5M ARM, 1.0 Cu.M HD / 993 KG BUCKET, 4200 KG COUNTERWEIGHT

Description	Shoe width	Operating weight	Ground pressure	Overall width
Units	mm	kg	kPa	mm
Triple grouser, HD	600	22338	0.51	2800

Specifications

				Recommended maximum material density (kg/m ³)	
Bucket type	Capacity	Cutting width	Weight	EC220 Q&A 5.7m HD Boom	
Direct Fit	GP	L	mm	kg	HD 2.5 m
		1220	1505	895	B
	HD	1600 RH	1840	820	A
		1000	1295	993	C

Maximum Material Density

A 1200~1300 kg/m³ Coal, Caliche, Shale

B 1400~1600 kg/m³ Wet earth and clay, Limestone, Sandstone

C 1700~1800 kg/m³ Granite, Wet sand, Well blasted rock

Optional arm 2.9 m

Please consult with your Volvo dealer for the proper match of buckets and attachments to suit the application. The recommendations are given as a guide only, based on typical operation conditions. Bucket capacity based on ISO 7451, heaped material with a 1:1 angle of repose.

Dimensions

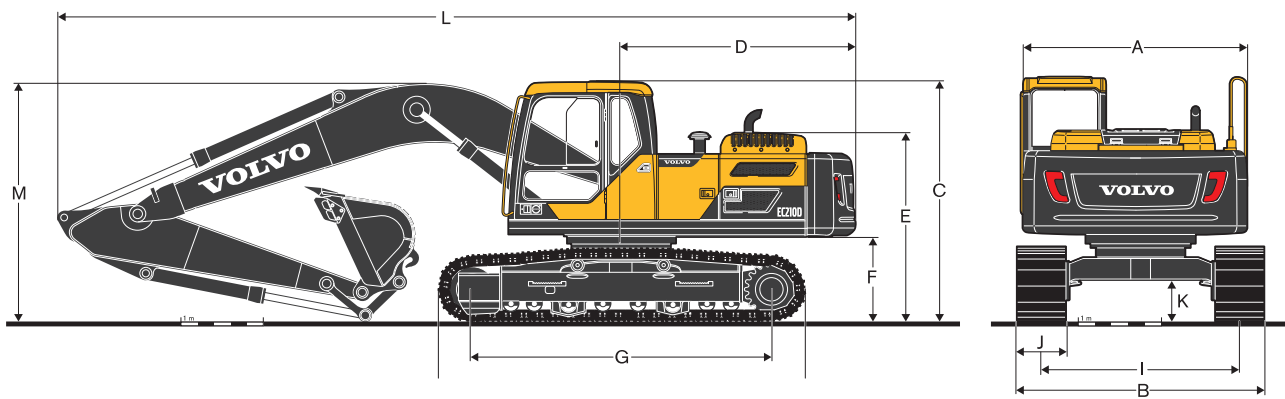

Description	Unit	EC220 Q&A
Boom	m	5.7
Arm	m	2.5
A Overall width of upper structure	mm	2700
B Overall width	mm	2800
C Overall height of cab	mm	2930
D Tail swing radius	mm	2850
E Overall height of engine hood	mm	2315
F Counterweight clearance*	mm	1025
G Tumbler length	mm	3370
H Track length	mm	4160
I Track gauge	mm	2200
J Shoe width	mm	600
K Min. ground clearance*	mm	460
L Overall length	mm	9745
M Overall height of boom	mm	3080

* Without shoe grouser

Specifications

		Boom		Arm
Description	Unit	Mono		
	m	5.7	2.5	
A	Length	mm	5910	3525.0
	Height	mm	1585	860.0
B	Width	mm	670	440.0
	Weight	kg	2110	1129.0

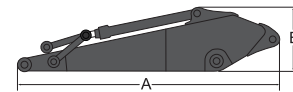
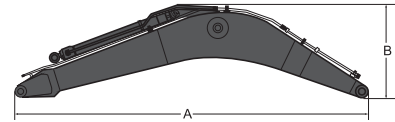

WORKING RANGES WITH DIRECT FIT BUCKET

Description	Unit		
Boom	m	5.7	
Arm	m	2.5	
A	Max. digging reach	mm	9580
B	Max. digging reach on ground	mm	9410
C	Max. digging depth	mm	6360
D	Max. digging depth (2.44m level)	mm	6140
E	Max. vertical wall digging depth	mm	5430
F	Max. cutting height	mm	9240
G	Max. dumping height	mm	6400
H	Min. front swing radius	mm	3670

DIGGING FORCES WITH DIRECT FIT BUCKET

Description	Unit	EC220 Q&A		
Boom	m	5.7		
Arm	m	2.5		
Bucket radius	mm	1503		
Breakout force bucket	Normal	SAE J1179	kN	120
	Power boost	SAE J1179	kN	127
	Normal	ISO 6015	kN	136
	Power boost	ISO 6015	kN	144
Tearout force - dipper arm	Normal	SAE J1179	kN	111
	Power boost	SAE J1179	kN	118
	Normal	ISO 6015	kN	114
	Power boost	ISO 6015	kN	121
Rotation angle, bucket	deg	175		

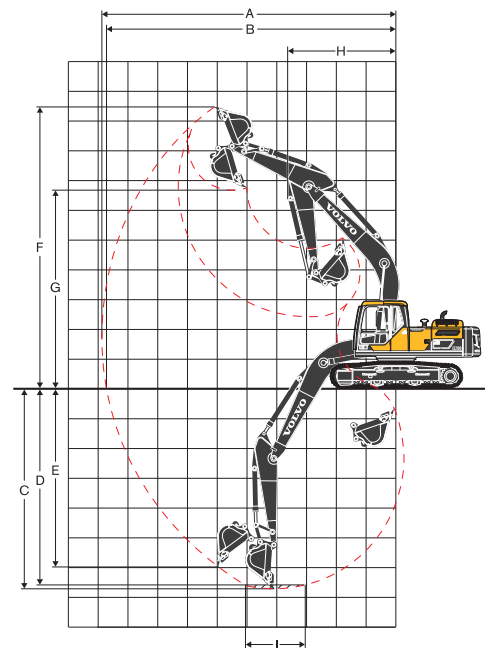

LIFTING CAPACITY EC220 Q&A

Lifting capacity at the arm end without bucket. For lifting capacity including bucket, simply subtract actual weight of the direct fit bucket or the bucket with the quick coupler from the following values.

	Lifting hook related to ground level		3.0 m		4.5 m		6.0 m		7.5 m		Max. reach		
			Along UC	Across UC	Along UC	Across UC	Along UC	Across UC	Along UC	Across UC	Along UC	Across UC	m
Boom: 5.7 m Arm: 2.5 m Shoe: 600 mm CWT: 4200 kg	7.5 m	kg									*5280	4930	5.6
	6.0 m	kg					*5120	4440			*5200	3500	6.9
	4.5 m	kg			*6520	*6520	*5600	4270	4560	2950	*4460	2880	7.6
	3.0 m	kg			*8380	6110	6320	4020	4460	2860	4040	2570	8.0
	1.5 m	kg			9430	5620	6060	3780	4340	2750	3890	2460	8.1
	0 m	kg			9170	5400	5880	3630	4260	2670	3980	2500	7.9
	-1.5 m	kg	*10270	*10270	9130	5370	5830	3580			4370	2730	7.4
	-3.0 m	kg	*13680	10550	9250	5470	5910	3660			5330	3330	6.5
	-4.5 m	kg	*10530	*10530	*7520	5760					*6610	5040	5.0

Volvo CE Dealer Network

India

Advanced Construction Technologies Pvt. Ltd.

Tamil Nadu, Andaman & Nicobar, Pondicherry and Lakshadweep

Dealer Partner: Mr. Siddharth Raman
Ph: +91 44 33511777
Email: siddarth.raman@actind.com

Alpha Teknisk Pvt. Ltd.

Delhi-NCR, Haryana, Uttaranchal

Dealer Partner: Mr. Manoj Kotru
Ph: +91 11 40744300 / 41679193
Email: mkotru1956@yahoo.co.in / m.kotru@alphatechnical.in

Alpha Teknisk Pvt. Ltd.

Uttar Pradesh

Dealer Partner: Mr. Sarthak Kotru
Ph: +91 522 4060238
Email: sarthak@alphatechnical.in

BSES India Pvt. Ltd.

Southern Rajasthan

Dealer Partner: Mr. Kedar Singh Rathore
Mr. Dhruvraj Singh Rathore
Ph: +91 0294 2640036 / 98290 41246
Email: ksathore@bsesindia.com
dhruvraj@bsesindia.com

DRS Earthwork Pvt. Ltd.

Northern Maharashtra

Dealer Partners: Mr. Rajiv Sabhlok /
Mr. Divish Sabhlok
Ph: +91 92346 24600 / 98997 93431
Email: rajivsabhlok@gmail.com,
divishsabhlok14@gmail.com

Encore Heavy Machinery Pvt. Ltd.

Karnataka

Dealer Partner: Mr. Vinayak Nayak
Ph: +91 80 2970 4009
Email: vinayak@encorece.in

ESDEE Solutech

Northern Rajasthan

Dealer Partner: Mr. O P Dawar
Ph: +91 0141 6502220
Email: op.dawar@esdeesolutech.net

International

Solution Engineering Ltd.

Bangladesh

Dealer Partner: Mr. Rashed Chowdhury
Ph: +880 1819312618
Email: rashed.chowdhury@sel-pti.com.bd

Explore Earth Movers Pvt. Ltd.

Nepal

Dealer Partner: Mr. Sushil Shrestha
Ph: +977 985 1107251
Email: sushil@exploreintl.com

Infra Equip Pvt. Ltd

Jharkhand

Dealer Partner: Mr. Dinesh Pandey
Mr. Naren Pandey
Ph: +91 70701 92500
Email: sales.support@infraequip.com

Navin Infrasolutions Pvt. Ltd.

Madhya Pradesh

Dealer Partners: Mr. Navin Bhandari
Ms. Seema Bhandari
Mr. Nilesh Bhandari
Ph: +91 0731 2434757,
+91 0731 2435621
Email: navinbhandari@navininfra.com
seemabhandari@navininfra.com
nileshbhandari@navininfra.com

PACT Machines Pvt. Ltd.

Kerala

Dealer Partner: Mr. Siddharth Raman
Ph: +91 484 2671755
Email: siddarth.raman@actind.com

PAL Infrastructure Solutions

Jammu & Kashmir, Himachal Pradesh,
Punjab and Chandigarh

Dealer Partner: Mr. Nishant Luthra
Ph: +91 176 2530632, +91 176 2522667
Email: nishantluthra@luthragroup.net

Pollutech Engineering

Orissa

Dealer Partner: Mr. Dilip Tripathy
Ph: +91 674 2585477
Email: dilip@pollutech.in

Ramanand Power Systems Pvt. Ltd.

Telangana and Andhra Pradesh

Dealer Partner: Mr. Rama Rao
Mr. Anand Anumolu
Mr. Nagarjuna Mandava
Ph: +91 98451 50173 / 94920 54224
+91 99909 75051
Email: sreeram@ramanand.co.in
anand@ramanand.co.in
nagarjuna@ramanand.co.in

A B Constructions Limited

Bangladesh

Dealer Partner: Mr. Mursalin Ahmad
Ph: +880 1711-207295
Email: mursalin@abcl.com.bd

Dax Engineering Co. (Pvt) Ltd.

Sri Lanka

Dealer Partner: Mr. Wijayasinghe SS
Ph: +94 714273900 / +94 714273920
Email: wije@daxholdings.lk

Suchita Millennium Projects Pvt. Ltd.

West Bengal, Sikkim and Bihar

Dealer Partner: Mr. Raghupati Bhuwalka
Ph: +9133 22197951, 7952 / 3183
Email: raghupatibhuwalka@suchitagroup.com

Suchita Earth Moving Solutions

Assam, Tripura, Meghalaya, Nagaland,
Mizoram, Arunachal Pradesh and Manipur

Dealer Partner: Ms. Amita Bhuwalka
Ph: +91 0361 2344513
Email: amitabhwalka@suchitagroup.com

SVP Mining Technologies Pvt. Ltd.

Chhattisgarh

Dealer Partner: Mr. Pramood Patwardhan
Ph: +91 84350 05500
Email: pramod@svpgroup.net

Team Engineers

Southern Maharashtra and Goa

Dealer Partners: Mr. Ajit Bafna
Mr. Shridhar Bhat
Mr. Anand Rajore
Ph: +91 93701 45680 / 93701 45660
+91 98220 33202

Email: ajit@teamengineers.co.in
srb@teamengineers.co.in /
anand.rajore@teameng.co.in

West India Equipments Pvt. Ltd.

Gujarat, Dadra & Nagar Haveli and
Daman & Diu

Dealer Partner: Mr. Jesal Vora
Ph: +91 98256 09097
Email: jesal.vora@gmail.com
jesal@westindiaequip.com

Riwang Heavy Equipment and Services

Bhutan

Dealer Partner: Mr. Rinzy Wangchuk
Ph: +97 517111965
Email: rinzy@riwangs.com